

# Set-up to measure mismatch for a VSG under large-signal conditions

A tickler signal from a second VSG excites the VSG-under-test ( $a_2$ ). The tickler signal is swept in phase.

Any reflection of the tickler signal off the VSG-under-test ( $b_2$ ) corresponds to mismatch, that is,  $\Gamma$  or  $\Gamma' \neq 0$ .

Port 1 is used to establish a phase reference, and is terminated in  $50\Omega$

The unmodulated carrier from the VSG-under-test was used to provide a phase reference for the measurements (the 10 MHz reference had too much jitter in the GHz range)

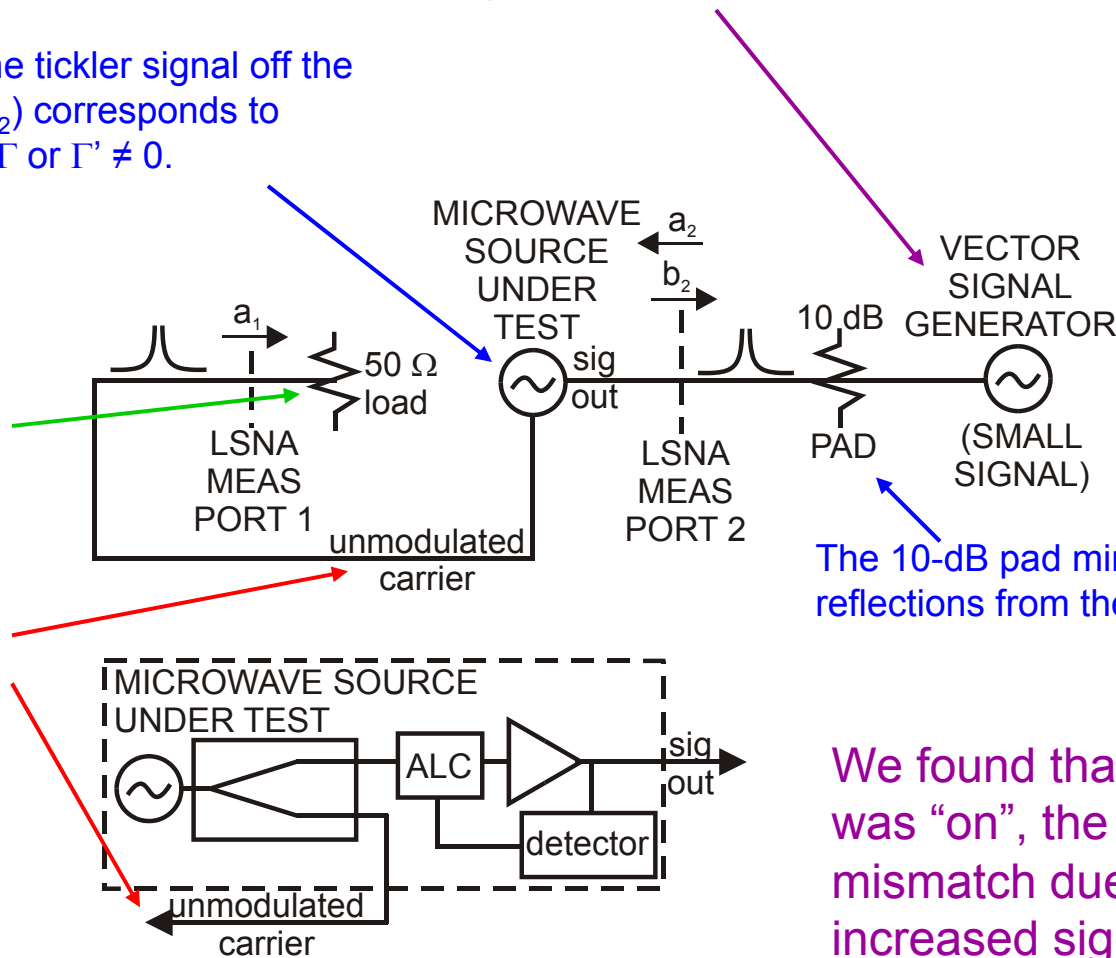

We found that when the ALC was "on", the component of mismatch due to  $\Gamma'$  increased significantly.

