

Advancements in Phase De-trending



Marc Vanden Bossche

Agenda

- **Motivation**
- Phase Alignment: CW – Harmonics
- Phase Alignment: Modulation
- Conclusion

Motivation

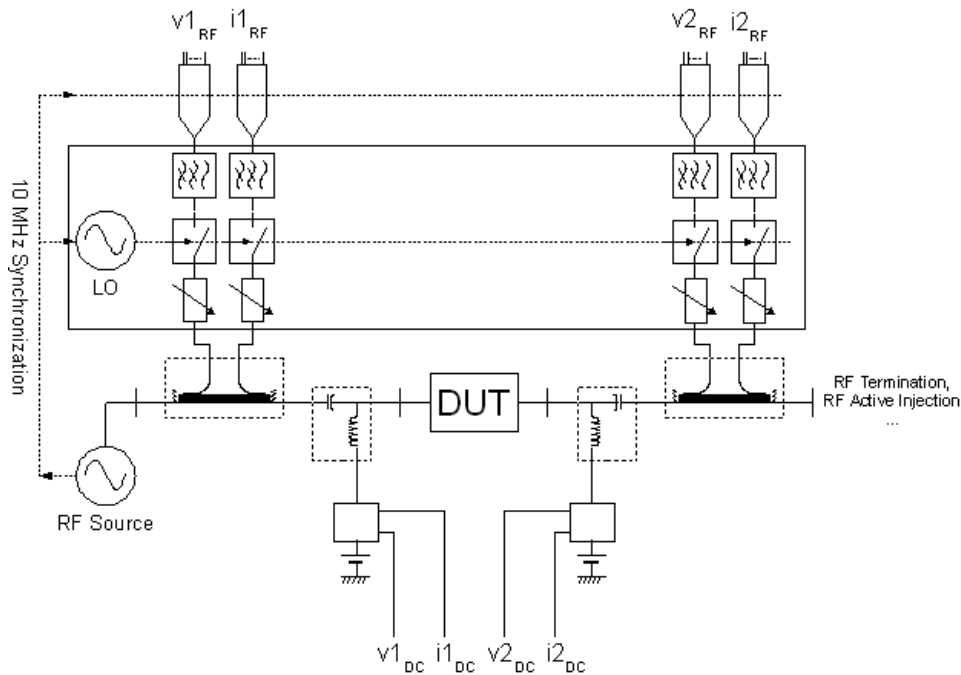

10 MHz Ref signal between RF Source, LO and ADC



At each measurement i:

- No Trigger ► unknown delay τ_i
- LO ► unknown phase offset ϕ_i

CW - Harmonics

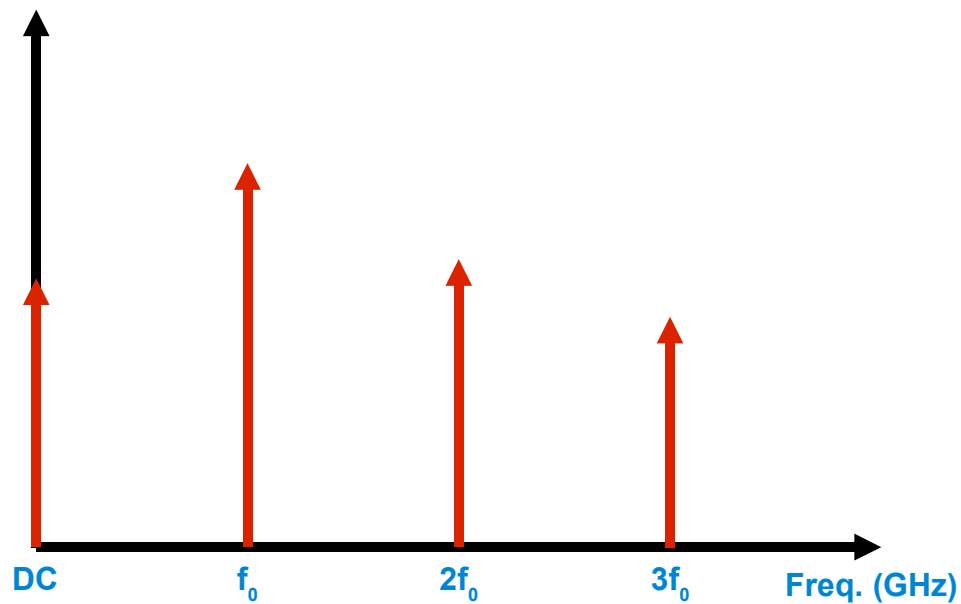

$$2\pi\tau_i \cdot f_0 \quad 2\pi\tau_i \cdot 2f_0 \quad 2\pi\tau_i \cdot 3f_0$$

$$\phi_i \quad 2\phi_i \quad 3\phi_i$$

$$X_i(kf_0) = X(kf_0) e^{jk(2\pi\tau_i f_0 + \phi_i)}$$

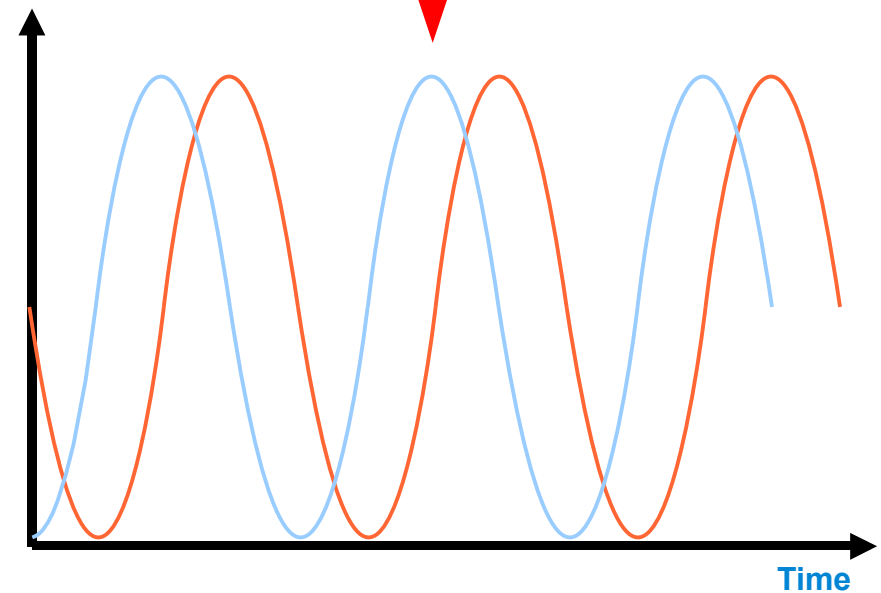
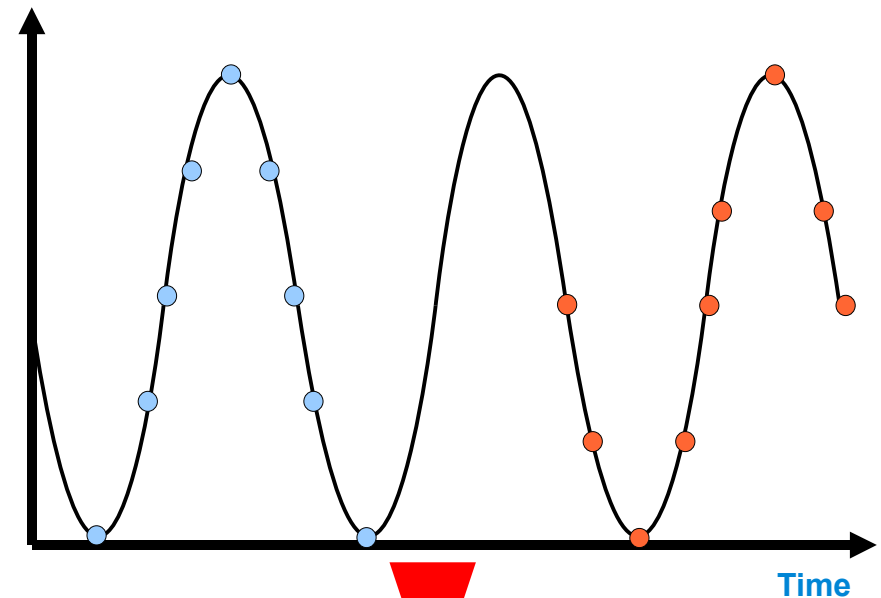

CW – Harmonics

Phase Alignment

- Visualization: phase normalization to a fixed Phase(a1(f₀)) (=0)

$$a'_x(kf_0) = a_x(kf_0) \cdot \left(\frac{a_1^*(f_0)}{|a_1(f_0)|} \right)^k$$

$$b'_x(kf_0) = b_x(kf_0) \cdot \left(\frac{a_1^*(f_0)}{|a_1(f_0)|} \right)^k$$

$x \in \{1, 2\}$ Port

$k \in \{0, 1, \dots, H\}$ Harmonic Index

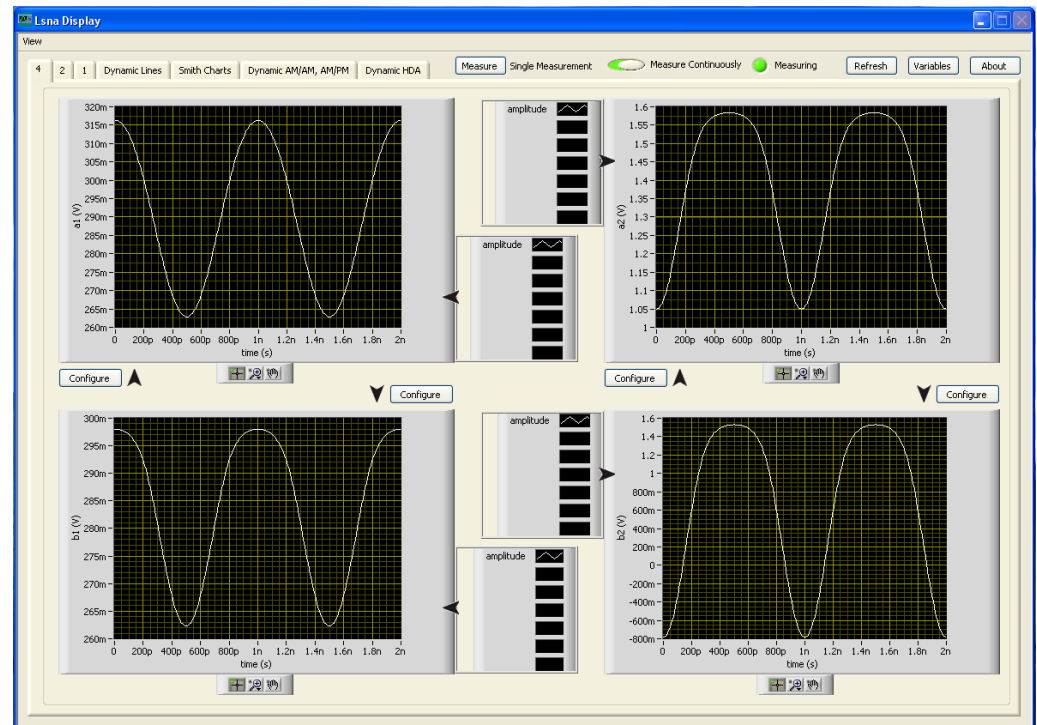

CW – Harmonics

Phase Alignment

- Averaging: Least Square Approach

$$\min_{\tau_i} \mathbf{S} = \sum_{k=0}^H |\mathbf{X}_0(kf_0) - \mathbf{X}_i(kf_0) e^{j2\pi kf_0 \tau_i}|^2$$

1500 experiments

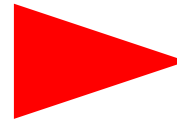
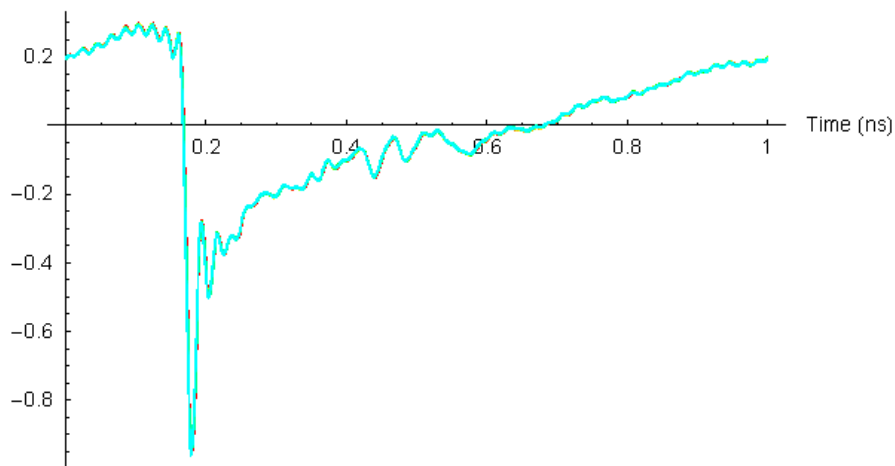

Averaged

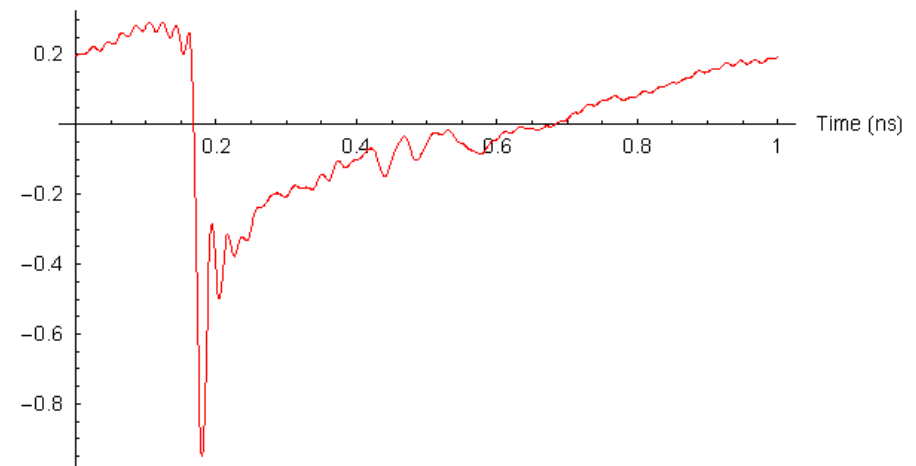

Modulation

Frequency Domain

$$X_i(kf_0, nf_m) = X(kf_0, nf_m) e^{j2\pi\tau_i(kf_0 + nf_m)} e^{jk\phi_i}$$

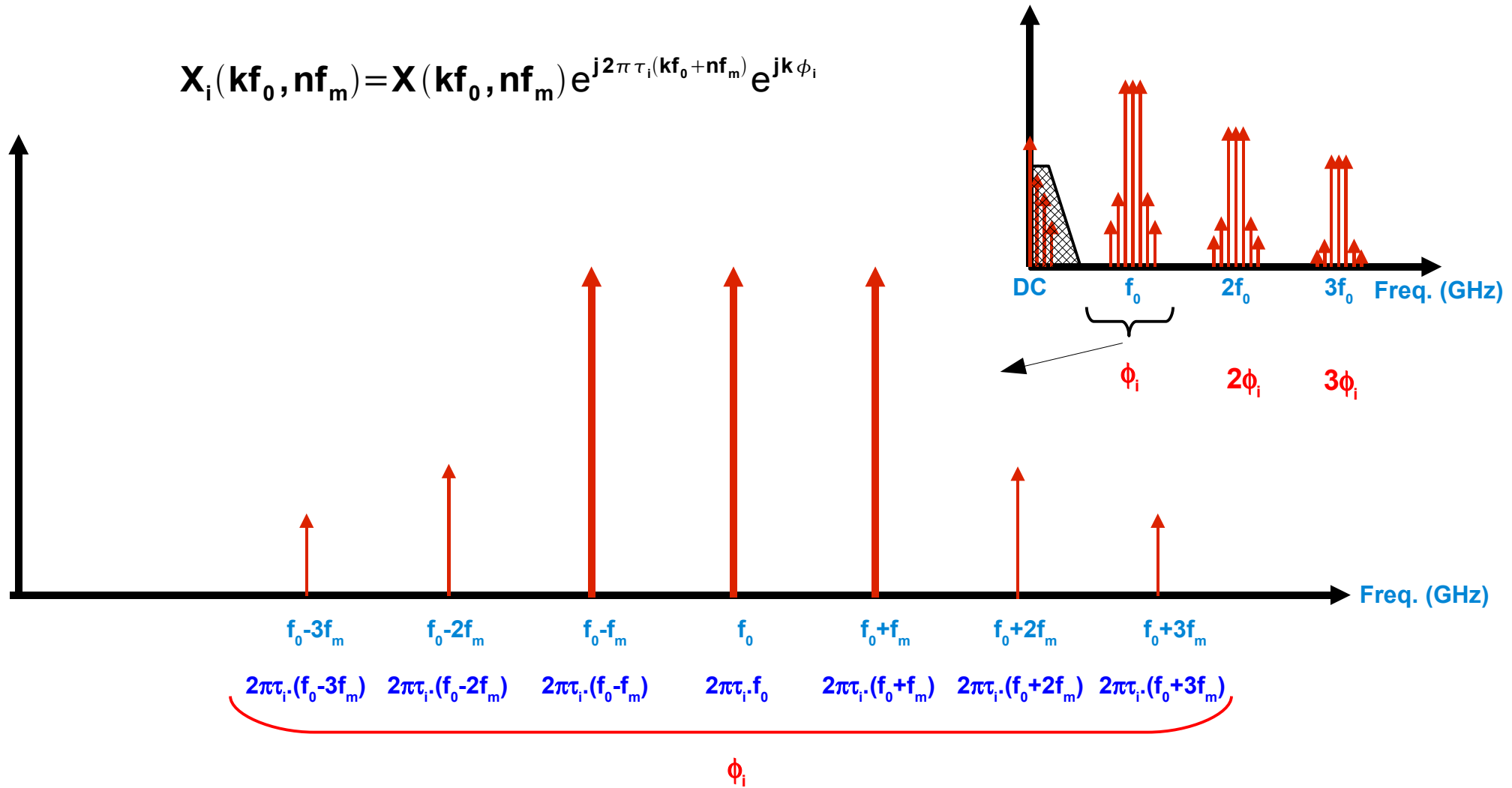

Modulation

Time Domain

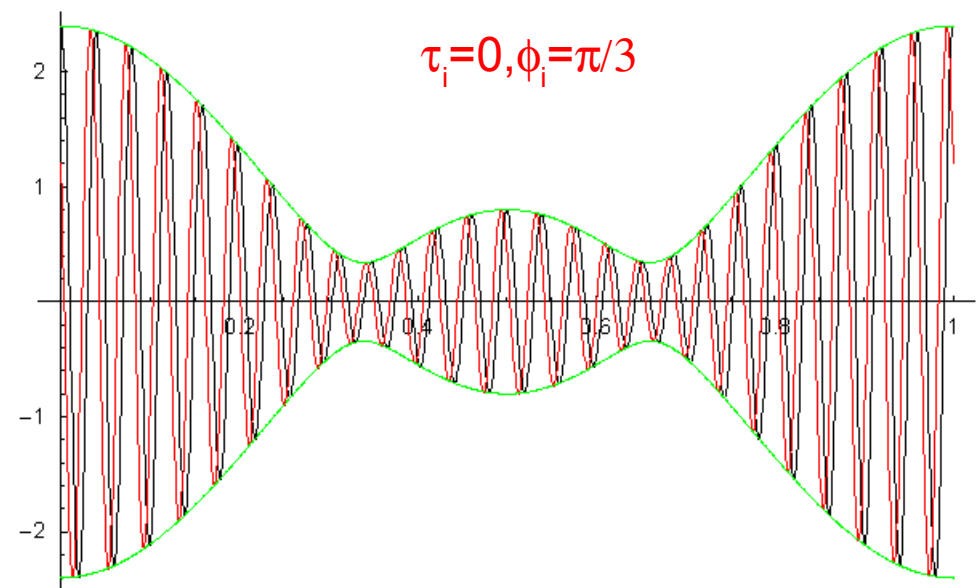
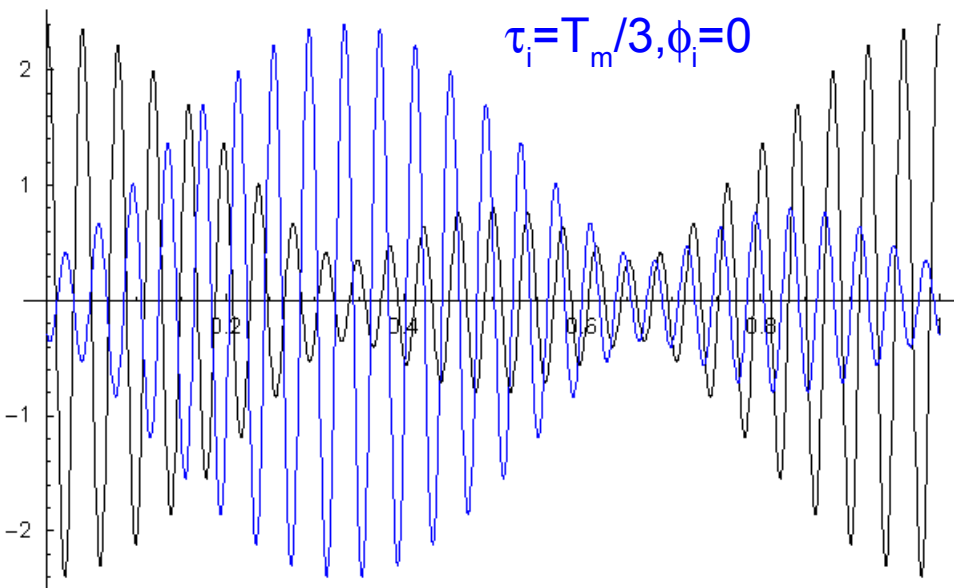
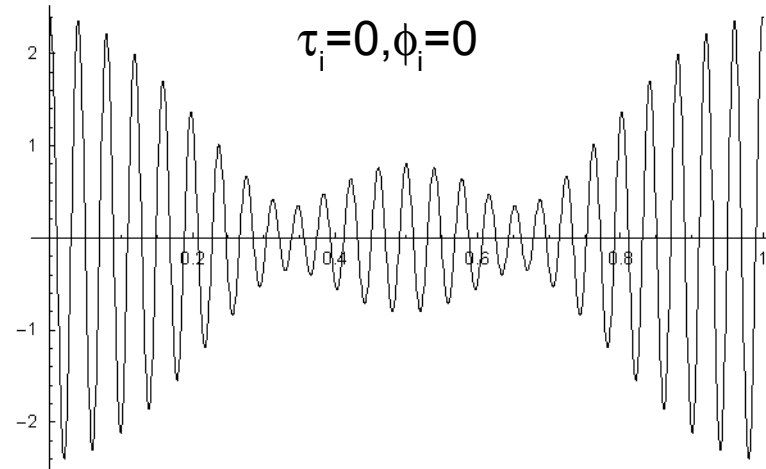

Modulation

Time Domain (cont'd)

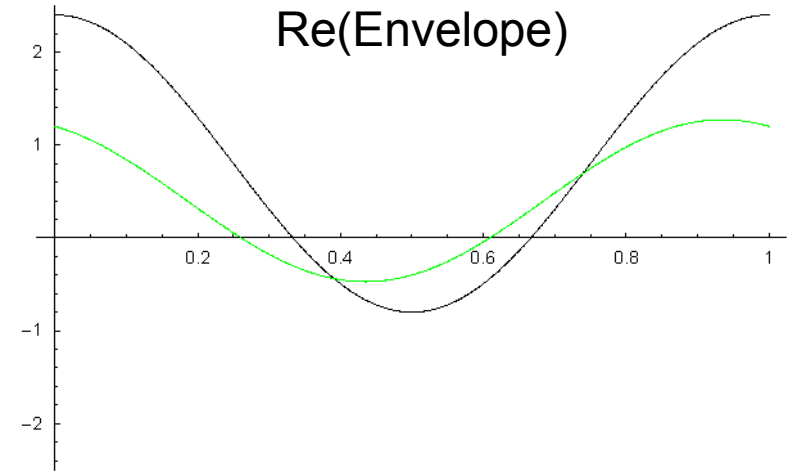
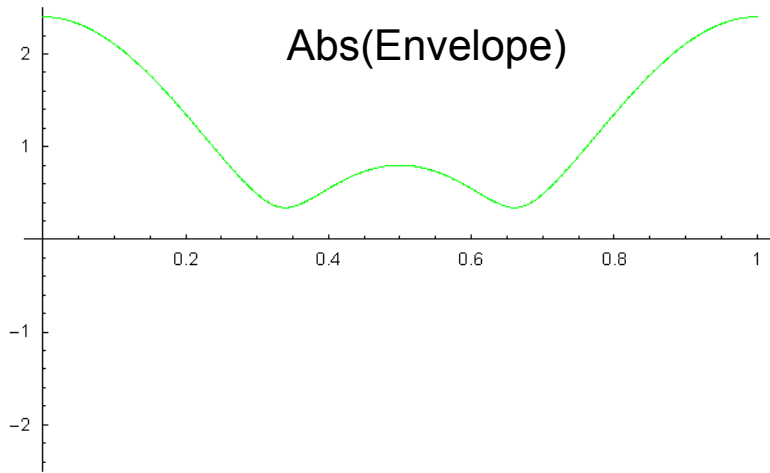

$$\tau_i=0, \phi_i=0$$
$$\tau_i=0, \phi_i=\pi/3$$

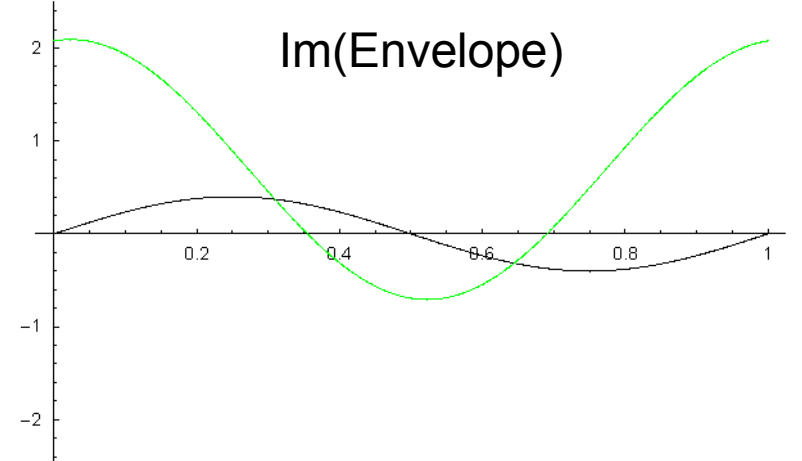
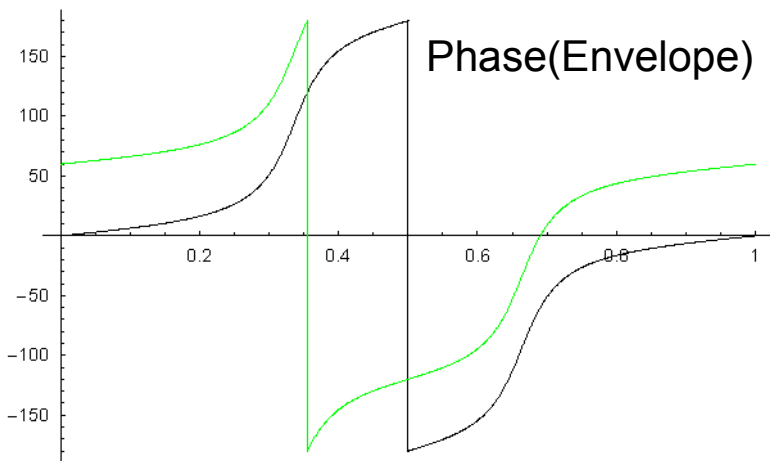

Modulation

Phase Alignment

1. Global Optimization
2. Simple Phase De-trending
3. Enhanced Phase De-trending

Modulation

- FET excited by a 3-Tones ($f_0 - f_m, f_0, f_0 + f_m$) modulated signal $f_0 = 1\text{GHz}$, $f_m = 50\text{kHz}$
- 50 measured tones each side of fundamental and harmonics

Phase Alignment

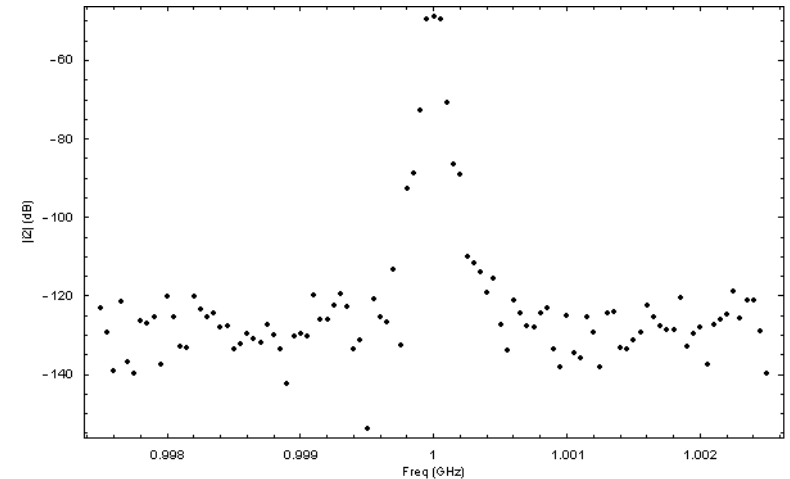

10 experiments

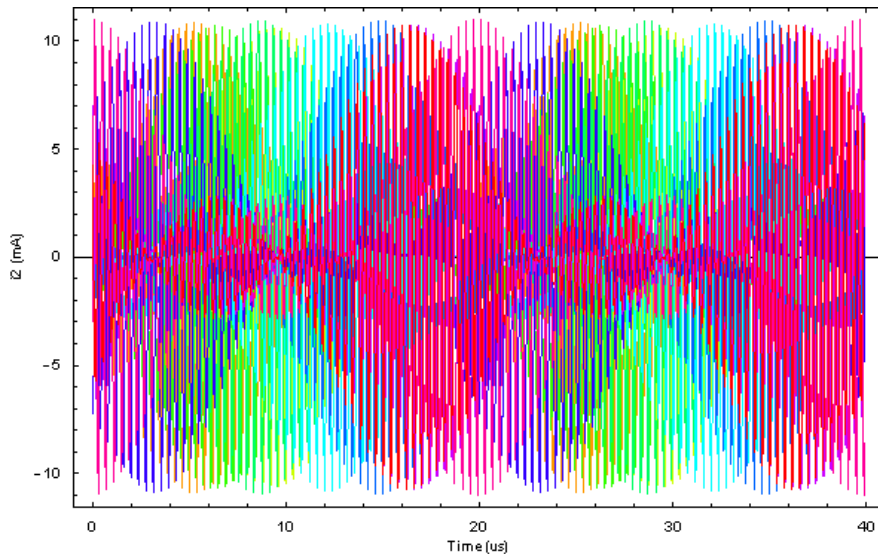

Aligned

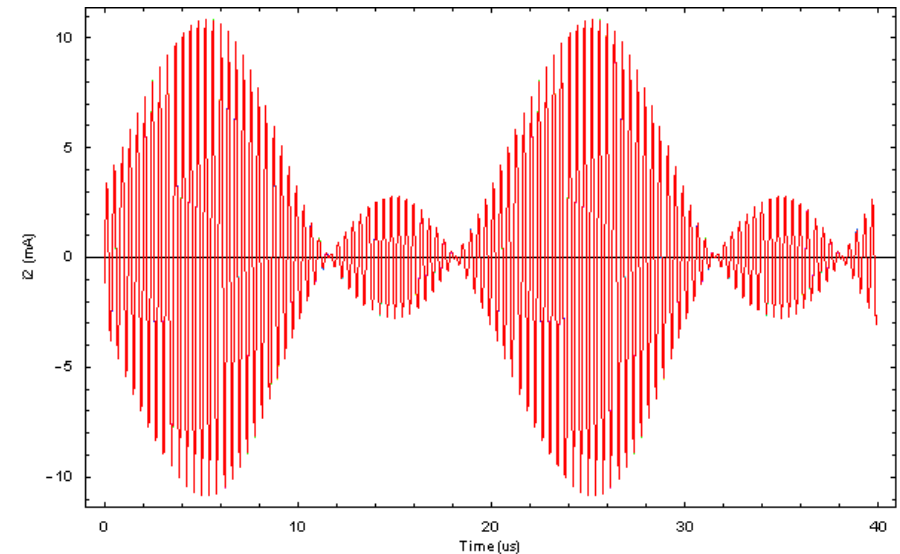

Modulation

Phase Alignment

Time Domain Waveform difference between first (reference) experiment and second experiment:

- simple alignment
- enhanced alignment
- global optimization

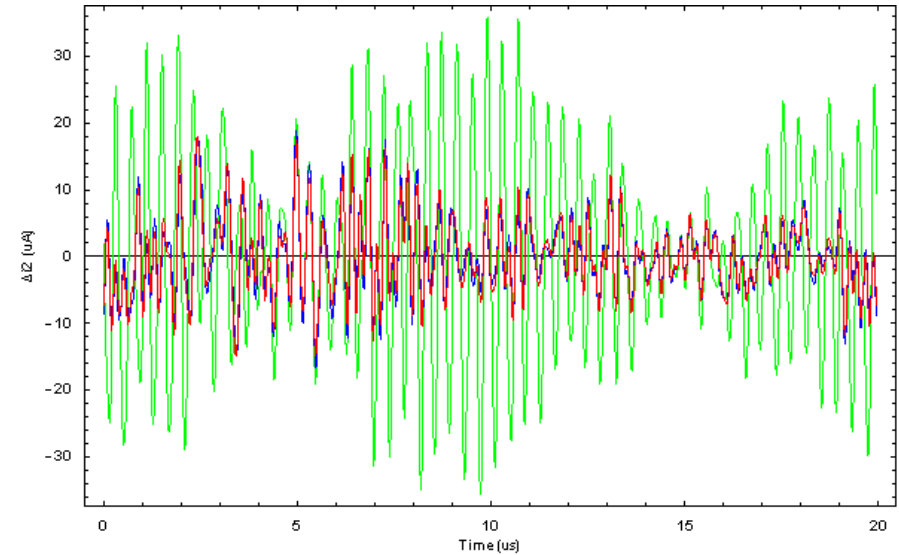

	Simple Alignment	Enhanced Alignment	Global Optimization
Consuming Time (s)	0.02	0.08	4.41

Conclusions

- Effect of unknown delay and phase offset:
 - In CW – Harmonics
 - In Modulation
- Overview of techniques to align experiments

Questions:

What is the importance of the carrier position inside the envelope?

Is it determinant for device characterization?